

AL 1250-CA - LOMBARDINI 12LD-477 DIESEL 3600 rpm | 60 Hz

**SINGLE PHASE
120 V**

TECHNICALS SPECIFICATIONS

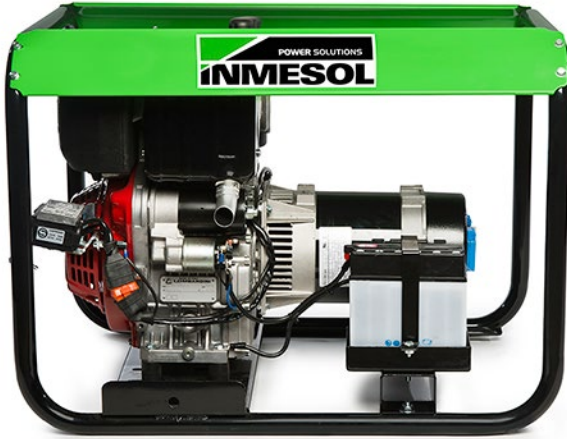

Image for guidance purposes.

Model:

AL 1250

Gen set composed of engine and alternator perfectly assembled and fitted in a practical tubular chasis, that is adding great strenght and versatility.

STANDBY POWER:
(LTP "Limited Time Power" norma ISO 8528-1) **12,5 kVA**

Genset general characteristics

Standby power LTP (kVA)	12,5
Frequency (Hz)	60
R.p.m.	3600
Voltage (V)	120
(Cos ϕ)	1

ENGINE CHARACTERISTICS

MAKE	MODEL		
LOMBARDINI	12LD-477		
Mechanical effect power (kWm)	15,7	Start	Automatic main failed
No. cylinders	2	Fuel	Diesel
Displacement (cm ³)	954	Fuel tank capacity (L)	15
Diameter x stroke (mm)	90x75	Fuel consumption 100% (L/h)	5
Compresion ratio	19:1	Oil tank capacity (L)	3
Cooling system	Air	Oil consumption (kg/h)	0,011
Series regulator	Mechanical	Battery V/Ah	12/19

AL 1250-CA - LOMBARDINI 12LD-477 DIESEL 3600 rpm | 60 Hz

**SINGLE PHASE
120 V**

ALTERNATOR CHARACTERISTICS

Voltage (V)	120
Frequency (Hz)	60
R.p.m.	3600
No. poles	2
Protection degree IP	21
Insulation	H

SOCKETS DESCRIPTION:

Depending on the market demand (optional)

DIMENSIONS AND WEIGHT

Lenght (mm)	980
Width (mm)	620
Height (mm)	650
Weight (kg)	150

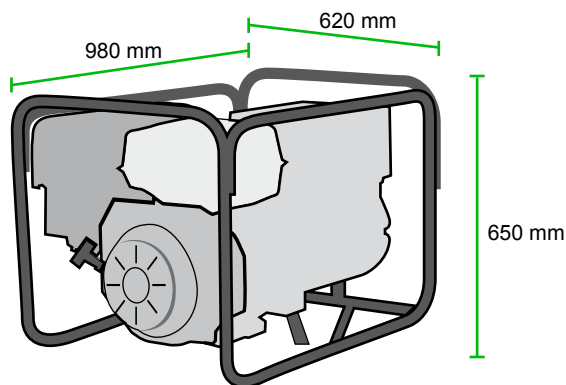

OPTIONAL

TRANSPORT KIT

DSE 6020 AUTOMATIC CONTROL PANEL WITH LOAD TRANSFER SWITCH PANEL

PROTECTION, DISTRIBUTION AND AUTOMATIC CONTROL panel which starts the generator set when it detects a mains failure and stops it when the mains is restored with the control unit DSE 6020. It also starts and stops the group manually via a pushbutton or remote start-up by contact.



Images for guidance purposes.

It has the following:

1 EMERGENCY STOP PUSHBUTTON

2 PROTECTIONS

- Protection fuses for control module.

3 BATTERY CHARGER

- 4 DSE 6020 PROTECCION CONTROL MODULE.** It has a digital LCD screen, which provides easy reading of the information regarding the **ENGINE, ALTERNATOR, MAINS and CHARGING.**

READINGS that can be made:

ENGINE:

- Cooling temperature
- Oil pressure
- Turning speed (rpm)
- Fuel level
- Battery voltage
- Battery alternator voltage
- Operating hours
- Number of start-ups

ALTERNATOR AND CHARGE:

- Voltages between phases and between phases and neutral.
- Intensities
- Frequency

MAINS:

- Frequency
- Voltages between phase and neutral (L-N)

CONTROL of the set:

- STARTS and STOPS the set when mains failure is detected and when it is restored, respectively
- It can also operate MANUALLY or REMOTELY via contact

Protection of the engine and alternator, with the ALARMS activated:

ENGINE:

- Low oil pressure
- High coolant temperature
- Low and High battery Voltage.
- Failure of the alternator to charge batteries
- Low fuel level.

ALTERNATOR:

- Low and High Voltage
- Low and High Frequency
- Overload due to Intensity (A)

MAINS:

- Low and High Voltage
- Low and High Frequency

OTHER CHARACTERISTICS:

- The real-time clock records the last 5 events.
- Configurable inputs and outputs.
- Configurable alarms and timers.
- USB connectivity
- Fully configurable via software and PC.
- Communication via USB cable for remote control
- Programmer Clock which starts and stops the set on a weekly basis for maintenance, etc..
- ALTERNATIVE CONFIGURATIONS, which open up the working possibilities

5 DISTRIBUTION :

- Direct output of the magnetothermal switch.

6 ▪ 2 POLES SWITCH BOARD.