

AL 700-CA - LOMBARDINI 15LD-440 DIESEL 3600 rpm | 60 Hz

**TRIPHASE
220/127 V**

TECHNICALS SPECIFICATIONS



Image for guidance purposes.

Model:

AL 700

Gen set composed of engine and alternator perfectly assembled and fitted in a practical tubular chasis, that is adding great strenght and versatility.

STANDBY POWER:
(LTP "Limited Time Power" norma ISO 8528-1) **7 kVA**

Genset general characteristics

Standby power LTP (kVA)	7
Frequency (Hz)	60
R.p.m.	3600
Voltage (V)	220 / 127
(Cos ϕ)	1

ENGINE CHARACTERISTICS

MAKE	MODEL		
LOMBARDINI	15LD-440		
Mechanical effect power (kWm)	7,5	Start	Automatic main failed
No. cylinders	1	Fuel	Diesel
Displacement (cm ³)	441	Fuel tank capacity (L)	5
Diameter x stroke (mm)	86x76	Fuel consumption 100% (L/h)	2
Compression ratio	20,3:1	Oil tank capacity (L)	1,5
Cooling system	Air	Oil consumption (kg/h)	0,0048
Series regulator	Mechanical	Battery V/Ah	12/19

AL 700-CA - LOMBARDINI 15LD-440 DIESEL 3600 rpm | 60 Hz

**TRIPHASE
220/127 V**

ALTERNATOR CHARACTERISTICS

Voltage (V)	220 / 127
Frequency (Hz)	60
R.p.m.	3600
No. poles	2
Protection degree IP	21
Insulation	H

SOCKETS DESCRIPTION:

Depending on the market demand (optional)

DIMENSIONS AND WEIGHT

Lenght (mm)	810
Width (mm)	560
Height (mm)	590
Weight (kg)	114

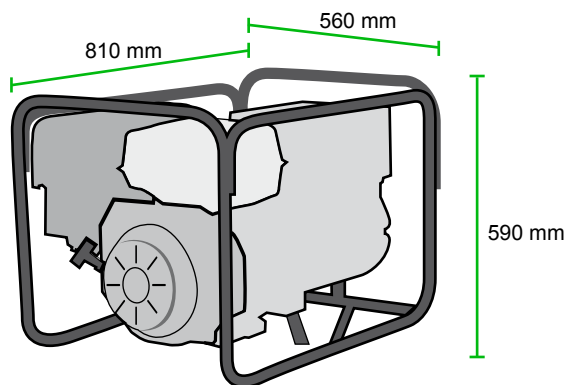

OPTIONAL

TRANSPORT KIT

AL 700-CA - LOMBARDINI 15LD-440 DIESEL 3600 rpm | 60 Hz

TRIPHASE
220/127 V

DSE 6020 AUTOMATIC CONTROL PANEL WITH LOAD TRANSFER SWITCH PANEL

PROTECTION, DISTRIBUTION AND AUTOMATIC CONTROL panel which starts the generator set when it detects a mains failure and stops it when the mains is restored with the control unit DSE 6020. It also starts and stops the group manually via a pushbutton or remote start-up by contact.



Images for guidance purposes.

It has the following:

1 EMERGENCY STOP PUSHBUTTON

2 PROTECTIONS

- Protection fuses for control module.

3 BATTERY CHARGER

AL 700-CA - LOMBARDINI 15LD-440 DIESEL 3600 rpm | 60 Hz

**TRIPHASE
220/127 V**

- 4 DSE 6020 PROTECCION CONTROL MODULE.** It has a digital LCD screen, which provides easy reading of the information regarding the **ENGINE, ALTERNATOR, MAINS and CHARGING.**

READINGS that can be made:

ENGINE:

- Cooling temperature
- Oil pressure
- Turning speed (rpm)
- Fuel level
- Battery voltage
- Battery alternator voltage
- Operating hours
- Number of start-ups

ALTERNATOR AND CHARGE:

- Voltages between phases and between phases and neutral.
- Intensities
- Frequency

MAINS:

- Frequency
- Voltages between phases and between phases and neutral (L1-N, L2-N, L3-N).
- Voltages between phases (L1-L2, L2-L3, L1-L3)

CONTROL of the set:

- STARTS and STOPS the set when mains failure is detected and when it is restored, respectively
- It can also operate MANUALLY or REMOTELY via contact

Protection of the engine and alternator, with the ALARMS activated:

ENGINE:

- Low oil pressure
- High coolant temperature
- Low and High battery Voltage.
- Failure of the alternator to charge batteries
- Low fuel level.

AL 700-CA - LOMBARDINI 15LD-440 DIESEL 3600 rpm | 60 Hz

**TRIPHASE
220/127 V**

ALTERNATOR:

- Low and High Voltage
- Low and High Frequency
- Overload due to Intensity (A)

MAINS:

- Low and High Voltage
- Low and High Frequency

OTHER CHARACTERISTICS:

- The real-time clock records the last 5 events.
- Configurable inputs and outputs.
- Configurable alarms and timers.
- USB connectivity
- Fully configurable via software and PC.
- Communication via USB cable for remote control
- Programmer Clock which starts and stops the set on a weekly basis for maintenance, etc..
- ALTERNATIVE CONFIGURATIONS, which open up the working possibilities

5 DISTRIBUTION :

- Direct output of the magnetothermal switch.

6 ▪ 4 POLES SWITCH BOARD.