

AK 1100-M - KOHLER CH 440/ GASOLINE 3600 rpm | 60 Hz

**TRIPHASE
220/127 V**

TECHNICALS SPECIFICATIONS



Model:

AK 1100

Gen set composed of engine and alternator perfectly assembled and fitted in a practical tubular chasis, that is adding great strenght and versatility.

STANDBY POWER:
(LTP "Limited Time Power" norma ISO 8528-1) **11 kVA**

Image for guidance purposes.

Genset general characteristics

Standby power LTP (kVA)	11
Frequency (Hz)	60
R.p.m.	3600
Voltage (V)	220/127
(Cos ø)	0.8

ENGINE CHARACTERISTICS

MAKE	MODEL
KOHLER	GH 440
Mechanical effect power (kWm)	8,9
No. cylinders	1
Displacement (cm ³)	429
Diameter x stroke (mm)	89x69
Compresion ratio	8,0:1
Cooling system	Air
Series regulator	Mechanical
Start	Recoil Start
Fuel	Gasoline
Fuel tank capacity (L)	7,3
Fuel consumption 100% (L/h)	4,1
Oil tank capacity (L)	1,1

AK 1100-M - KOHLER CH 440/ GASOLINE 3600 rpm | 60 Hz

**TRIPHASE
220/127 V**

ALTERNATOR CHARACTERISTICS

Voltage (V)	220/127
Frequency (Hz)	60
R.p.m.	3600
No. poles	2
Protection degree IP	21
Insulation	H

SOCKETS DESCRIPTION:

Depending on the market demand (optional).

DIMENSIONS AND WEIGHT

Lenght (mm)	740
Width (mm)	530
Height (mm)	520
Weight (kg)	86

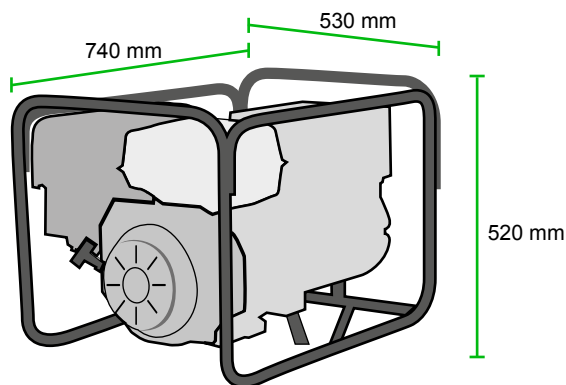

OPTIONAL

TRANSPORT KIT