

AH 700-CA - HONDA GX 390/ GASOLINE 3000 rpm | 50 Hz

**SINGLE PHASE
230 V**

TECHNICALS SPECIFICATIONS



Image for guidance purposes.

Model:

AH 700

Gen set composed of engine and alternator perfectly assembled and fitted in a practical tubular chasis, that is adding great strenght and versatility.

STANDBY POWER:
(LTP "Limited Time Power" norma ISO 8528-1) **7 kVA**

Genset general characteristics

Standby power LTP (kVA)	7
Frequency (Hz)	50
R.p.m.	3000
Voltage (V)	230
(Cos ø)	1

ENGINE CHARACTERISTICS

MAKE	MODEL
HONDA	GX 390
Mechanical effect power (kWm)	6
No. cylinders	1
Diameter x stroke (mm)	88x64
Compresion ratio	8,0:1
Cooling system	Air
Series regulator	Mechanical
Start	Automatic main failed
Fuel	Gasoline
Fuel tank capacity (L)	6,1
Fuel comsumption 100% (L/h)	3,4
Oil tank capacity (L)	1,1

AH 700-CA - HONDA GX 390/ GASOLINE 3000 rpm | 50 Hz

**SINGLE PHASE
230 V**

ALTERNATOR CHARACTERISTICS

Voltage (V)	230
Frequency (Hz)	50
R.p.m.	3000
No. poles	2
Protection degree IP	21
Insulation	H

SOCKETS DESCRIPTION:

Version SINGLE PHASEe : 2 PRISES SINGLE PHASEES SCHUKO 16A et protection thermique.

DIMENSIONS AND WEIGHT

Lenght (mm)	740
Width (mm)	530
Height (mm)	530
Weight (kg)	85

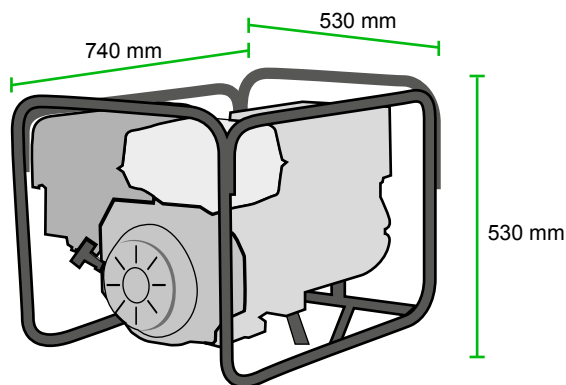

OPTIONAL

TRANSPORT KIT

AH 700-CA - HONDA GX 390/ GASOLINE 3000 rpm | 50 Hz

SINGLE PHASE
230 V

AUTOMATIC CONTROL PANEL WITH DSE LOAD TRANSFER SWITCH PANEL

PROTECTION, DISTRIBUTION AND AUTOMATIC CONTROL panel which starts the generator set when it detects a mains failure and stops it when the mains is restored with the control unit DSE. It also starts and stops the group manually via a pushbutton or remote start-up by contact.



Images for guidance purposes.

It has the following:

1 EMERGENCY STOP PUSHBUTTON

2 PROTECTIONS

- Protection fuses for control module.

3 BATTERY CHARGER

4 DSE PROTECCION CONTROL MODULE. It has a digital LCD screen, which provides easy reading of the information regarding the **ENGINE, ALTERNATOR** and **MAINS**.

READINGS that can be made:

ENGINE:

- Cooling temperature
- Oil pressure
- Turning speed (rpm)
- Fuel level
- Battery voltage
- Battery alternator voltage
- Operating hours
- Number of start-ups

ALTERNATOR AND CHARGE:

- Voltages between phase and neutral
- Frequency

MAINS:

- Frequency
- Voltages between phase and neutral (L-N)

CONTROL of the set:

- STARTS and STOPS the set when mains failure is detected and when it is restored, respectively
- It can also operate MANUALLY or REMOTELY via contact

Protection of the engine and alternator, with the ALARMS activated:

ENGINE:

- Low oil pressure
- Low and High battery Voltage.
- Failure of the alternator to charge batteries

ALTERNATOR:

- Low and High Voltage
- Low and High Frequency

MAINS:

- Low and High Voltage
- Low and High Frequency

OTHER CHARACTERISTICS:

- Configurable inputs and outputs.
- Configurable alarms and timers.
- USB connectivity
- Fully configurable via software and PC.
- Communication via USB cable for remote control
- Programmer Clock which starts and stops the set on a weekly basis for maintenance, etc..
- ALTERNATIVE CONFIGURATIONS, which open up the working possibilities

5 **DISTRIBUTION :**

- Direct output of the magnetothermal switch.